

BASED ON:-QST June, 2010 50W AMP

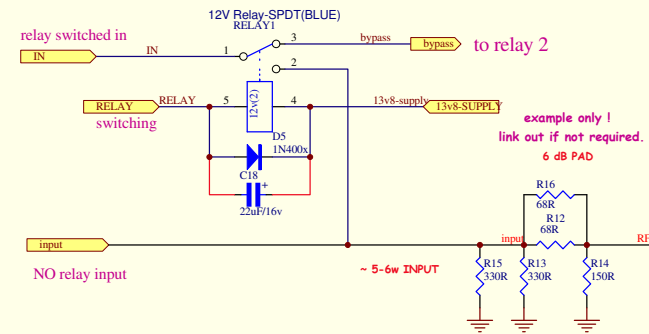
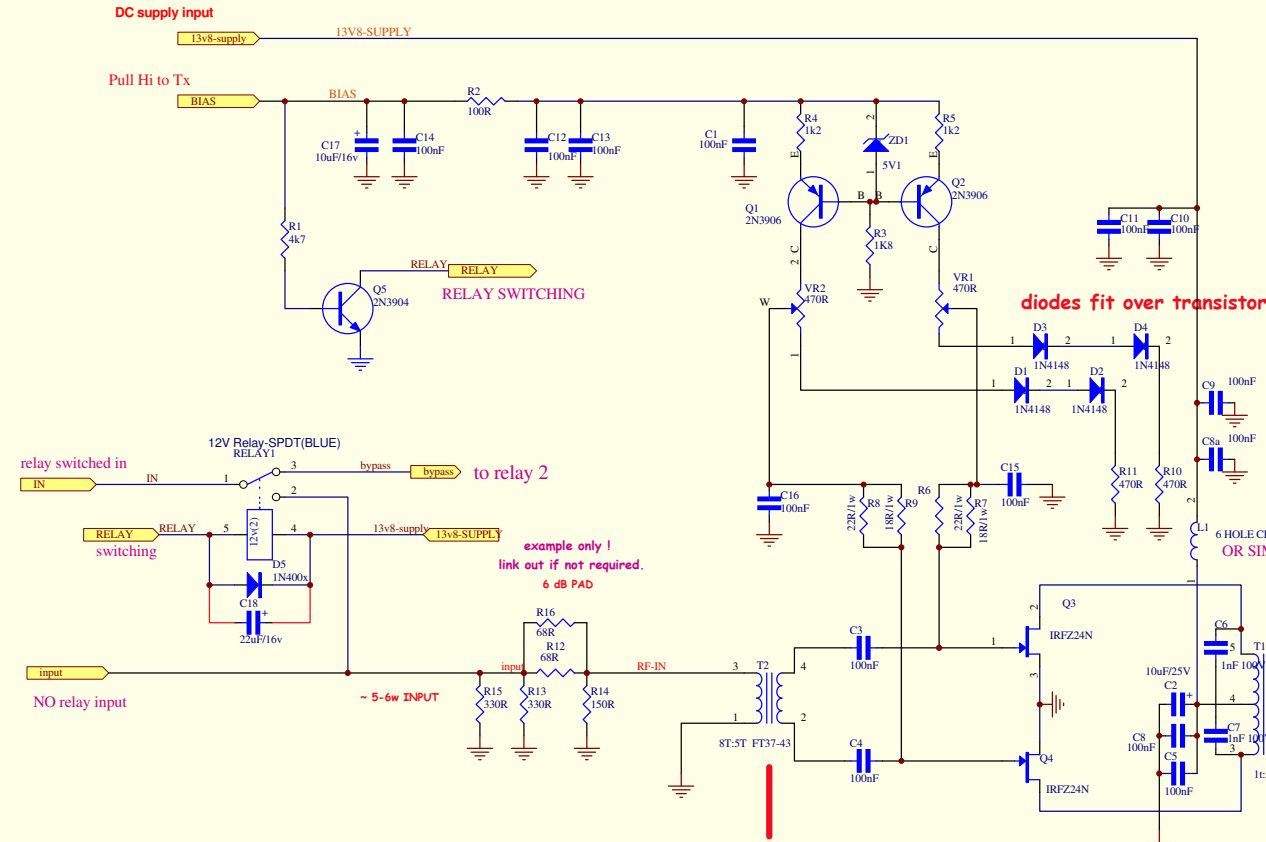

APPENDIX 1: Using other mosfets: the IRFZ34N or IRFZ34NPB

The author did some limited experimenting with a similar mosfet, the IRFZ34N. This is priced in the same range as the IRFZ24N, but is rated at 34 amps max, compared with 24 amps for the IRFZ24N. It has a lower ON resistance, but we don't get something for nothing, so it has about twice the capacitance of the IRFZ24N. This limits it further in high frequency performance but I was curious to see how it might work on the lower three HF bands, 40 through 160 meters. It does indeed appear to work somewhat better on these bands. The data below shows a capability of at least 50W output on 40, 80 and 160 meters, with low drive power of 1W or less (about 0.5W ON 160m gives 50W of output when biased at 100 mA per device). This is a gain of 100, or 20 dB, not bad for a device costing less than one dollar each. The IMD also met or exceeded the required -28 dBc on all these bands, at 12.5 watts per tone. So here is one way to improve performance on the lower HF bands.

Farnell have IRFZ34EPBF for AUD\$1.72 + gst 8650187. Input Cap is 680pF

The IRFZ34NPBF is 8650195 \$1.85+ Input Cap is 700pF

The original IRFZ24 is 8650160 and about \$3.00+gst Input Cap is 370pF

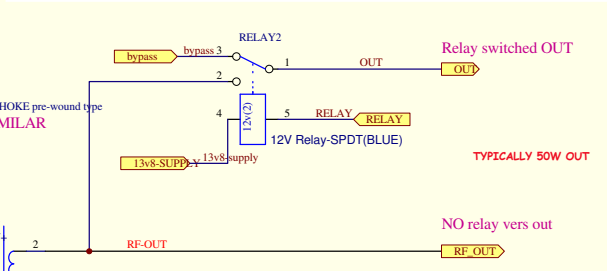

NOTE:- W6JL' original version with relays had the LPF before the output relay. This PCB assumes externally switched filters.

LATER_ changed this to a Balun core for better input SWR see web page (www.carnut.info)

20th June 2022, saved in higher resolution pdf.
 15th March tidy up MASTER
 Jan 2022 added relay RF switching
 March 2021 minor tidy up only
vk3pe 05-07-10

Title W6JL amp by vk3pe		DRAWN VK3PE	
Size: A3	Number:	Revision: Ver A Panel	(C) VK3PE 2020
File:		Date: 20-Jun-2022	Time: 10:33:46
		Sheet 1	of 1