

V2.0 pcb:- RF Board or Tracking Gen for "simpleSA"

Last printed 11-10-20

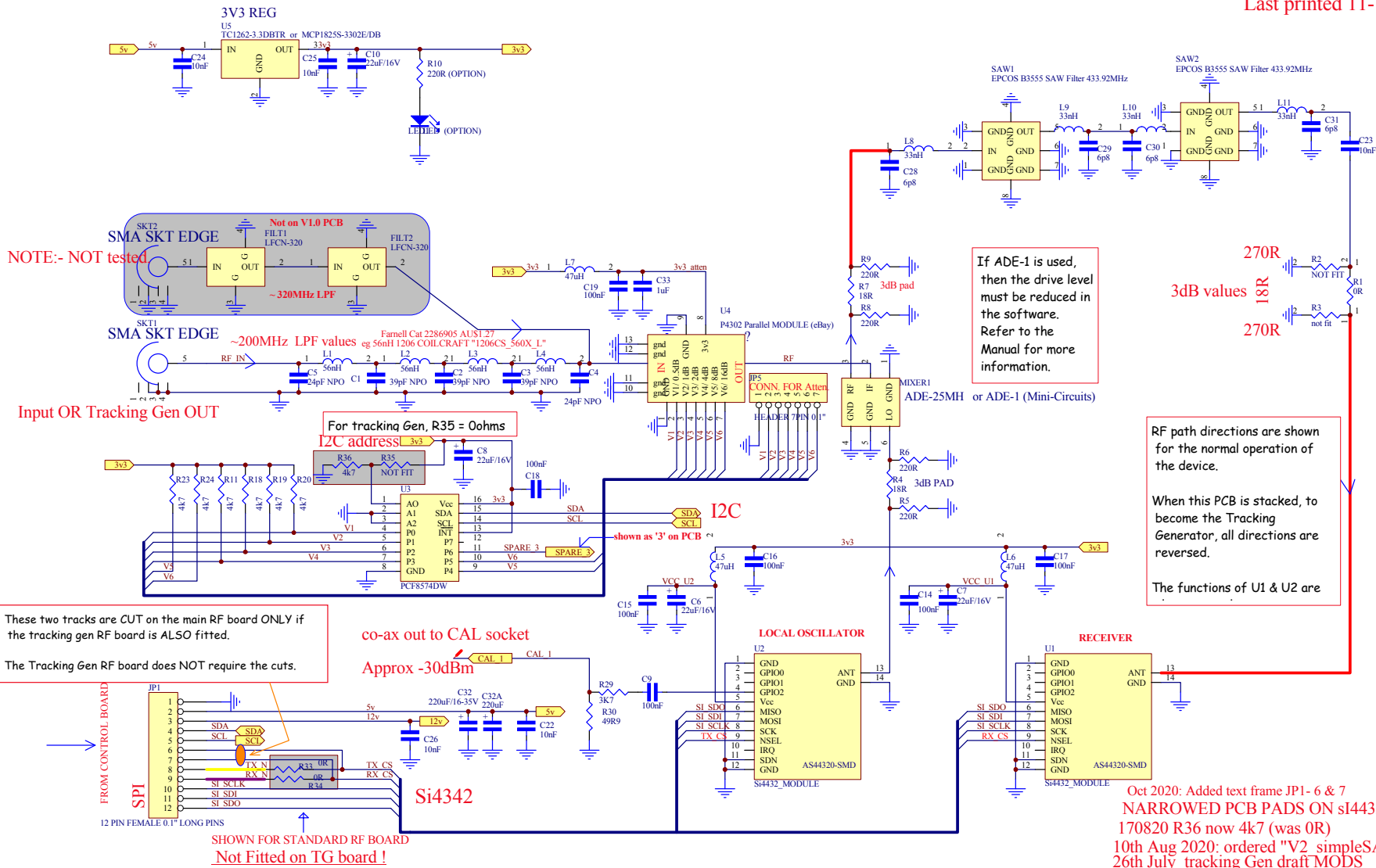

Oct 2020: Added text frame JP1- 6 & 7
NARROWED PCB PADS ON SI4432
 170820 R36 now 4k7 (was 0R)
 10th Aug 2020: ordered "V2_simpleSA.ZIP"
 26th July tracking Gen draft MODS

V3_TRACKa4.PCB
 ordered as "V2_simpleSA.ZIP"

Title	DRAWN BY: VK3PE	
Size: A3	Date: 12-Oct-2020 Time: 14:33:10	Sheet of 2 of 2
		(C) 2007-2019