

# IC-705 Bluetooth interface to external PA & LPF. (AND XPA-125)

Sept 27th, 2025  
Dec 2025

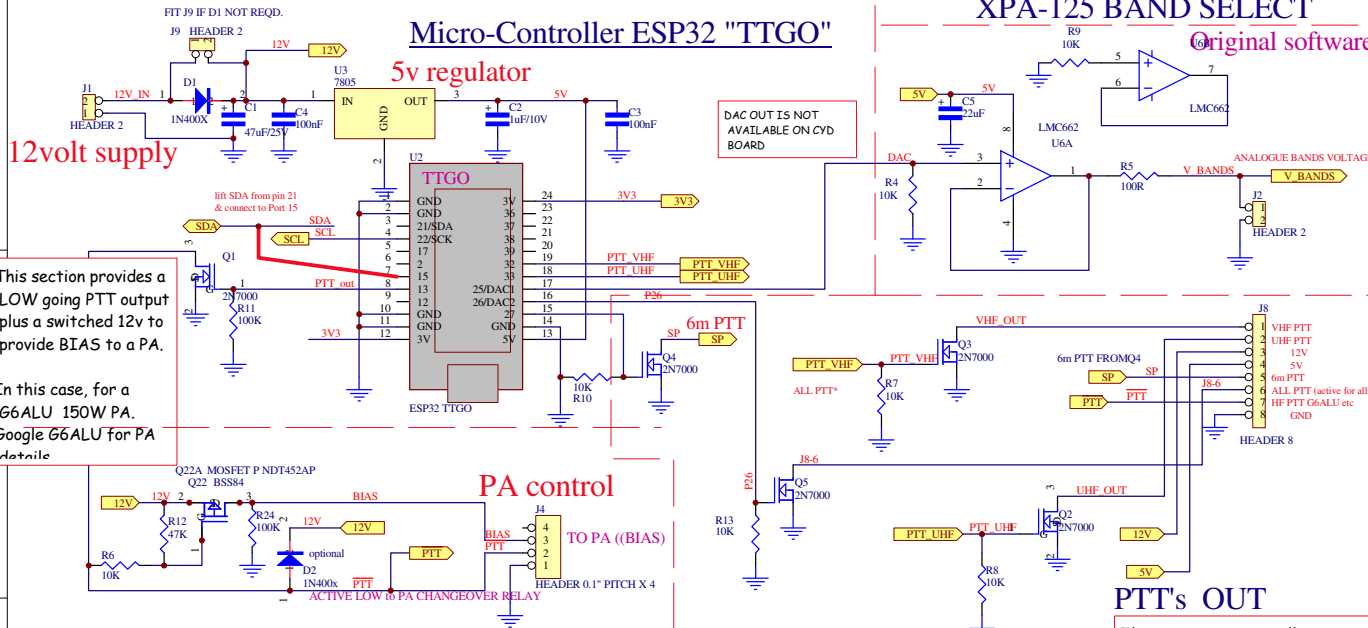

ICOM IC-705 BT adapter PCB  
 NEW PCB FOR ALL BANDS AND XPA-125 INTERFACE  
 It uses a TTGO board.  
 V3.0 pcb was made and tested.  
 V3.1 adds some minor fixes. but not made.

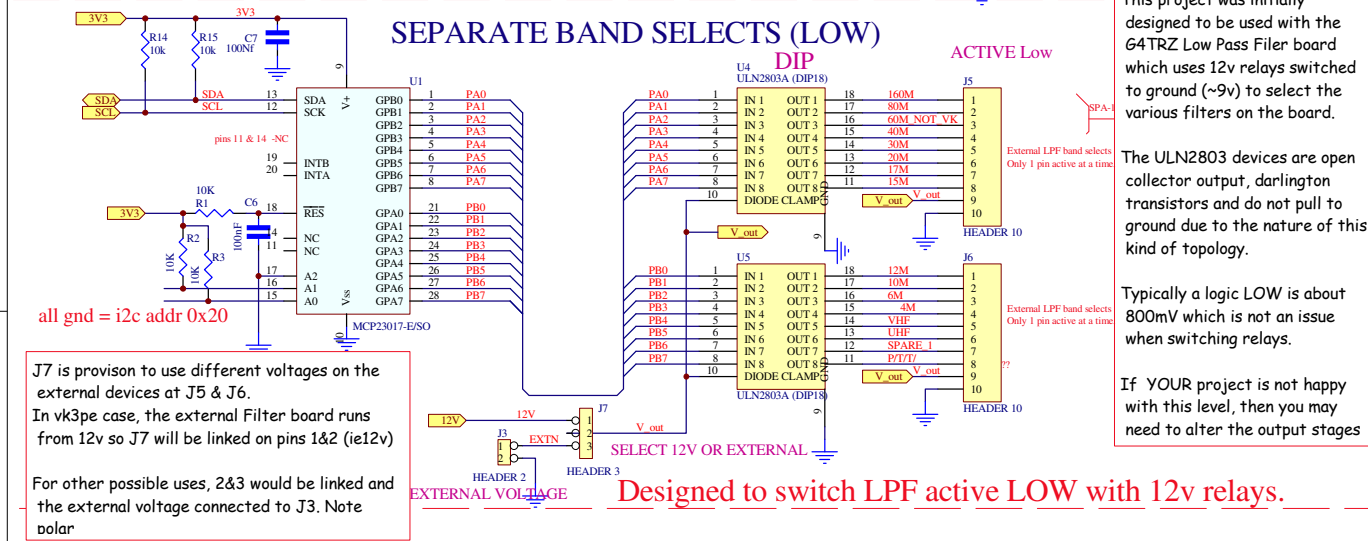

**G4TRZ 6-BAND LPF or similar (VK3PE ONLY)**  
 160M, 80M, 40M, 30/20M, 17/15M, 12/10M  
 \* 3 BAND only LPF PCB FOR VK3PE PROJECT  
 ACTIVE LOW

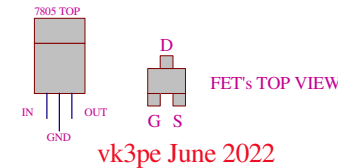

ORIGINAL CODE:- [https://github.com/Willybrook/CIV\\_template/Examples](https://github.com/Willybrook/CIV_template/Examples)  
 MODIFIED CODE:- [www.carnut.info](http://www.carnut.info) >> IC-705

V3.0 PCB is "....."

Title <b>IC-705 BLUETOOTH LPF &amp; PTT SWITCHING</b>			
Size: A3	Number:	Revision: Beta 3.0	(C) VK3PE 2022
File:		Date: 30-Dec-2025	Time: 19:01:02 Sheet 1 of 1