

K3NG ATU CONTROL SECTION v1.2 & 1.21 SMALL with OLED DISPLAY

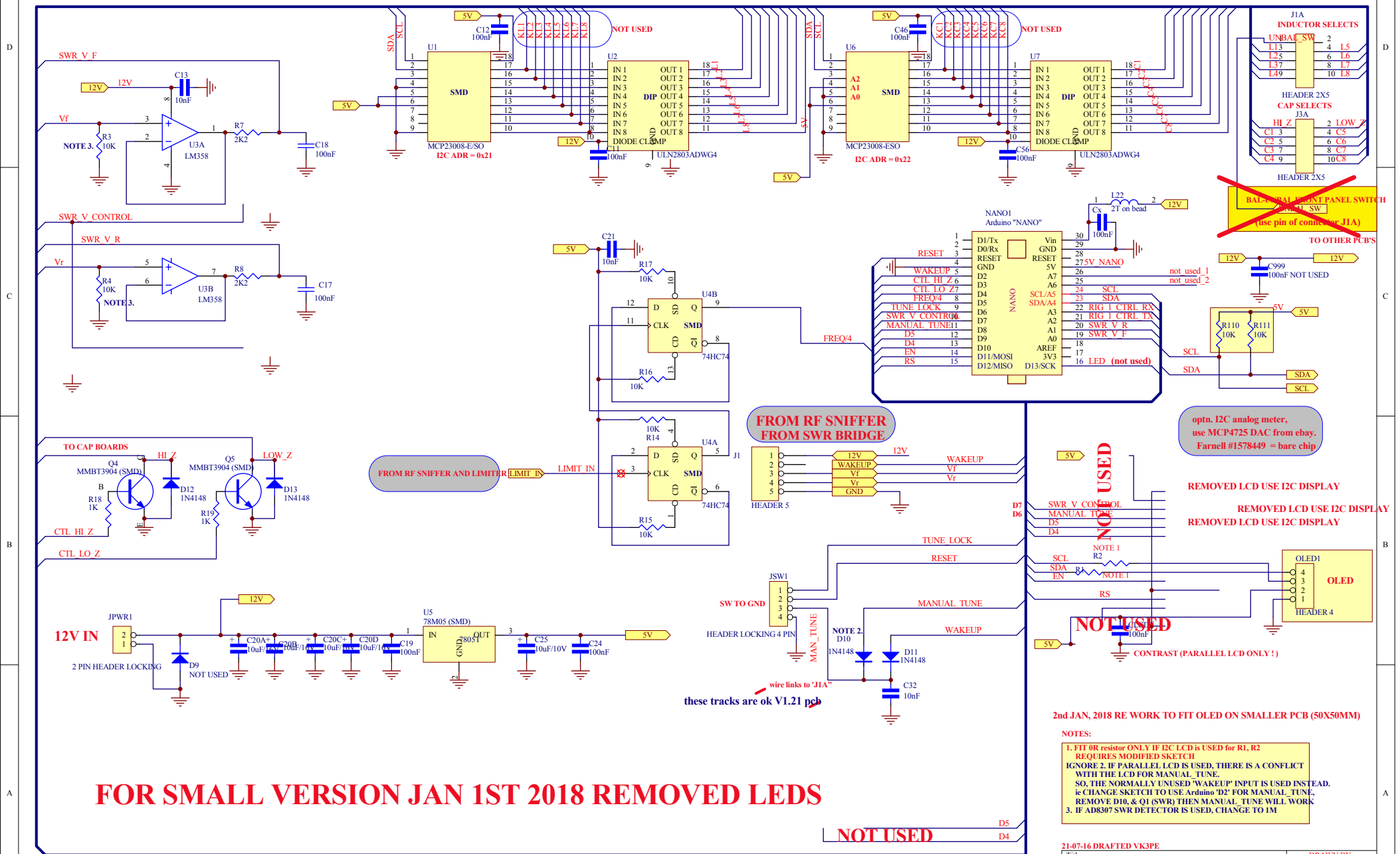

21-07-16 DRAFTED VK3PE		DRAWN BY: VK3PE	
Title: VERSION 1.2 K3NG ATU CONTROLLER PCB		Date: 3-May-2018	
Size: A3	Time: 12:51:42	Sheet 1 of 1	(C) 2007-2016
VERS 1.1 020916			