

TP41 POWER SUPPLY BOARD

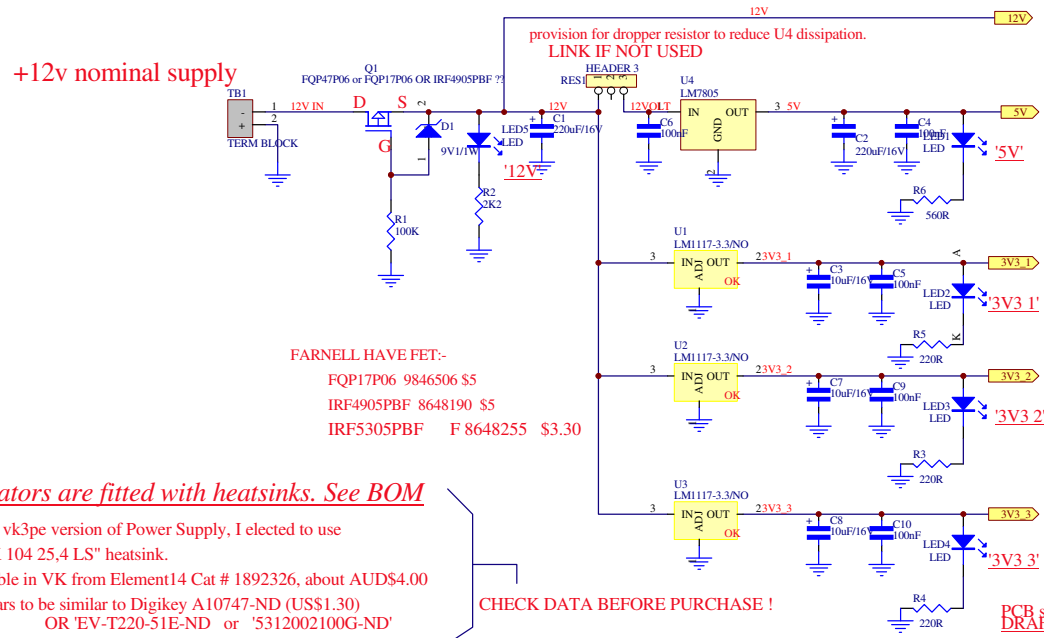
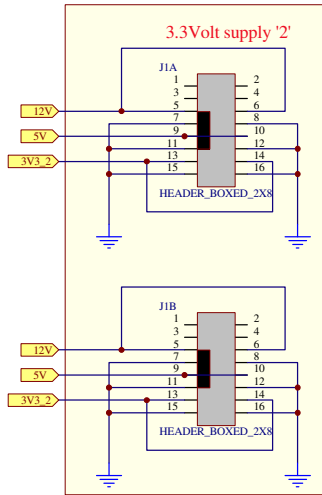
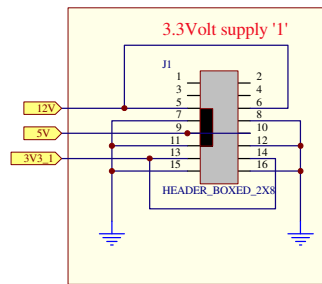

VK3PE PCB HAS MTG HOLES AT 25.4mm SPACING.

PCB sent to jlc 28th july 2024
 DRAFT 1.0 12TH JULY 2022, VK3PE

Title TP41 POWER SUPPLY BOARD		Revision: V010 6TH JUNE 2022 (C) VK3PE 2022	
Size: A3	Number:	Date: 31-Jul-2022	Time: 12:46:20
File:		Sheet 0 of 0	