

TO JP1 CONNECTOR (RIGHT SIDE OF SHEET)

Opto Encoder Sheet 4

TO DISPLAY SHEET

DSP LED (SEE STATUS SHEET)

CONNECTOR TO DDS & OPTO ENCODER

refer to keypad # follow net names for connections to JK1 connector

To Matrix board

This schematic is a re-drawn version of the G3XJP PnM schematic who owns the (C). This schematic is provided for completeness only for the VK3PE & C.S. pcb.

Update-1:- C2 was shown on Butler sheet, now on this sheet to reflect where it is actually fitted.
 NOTE C18 is changed by groups to 100nF for noise problems 15-03-07 z1-07-06 UPDATED bds TO DIF28 14-06-08
 Updated on: 13-17-59 Updated by: 09-06-06

each box below is a sheet in PnM schematic

Name PnM Ver-a BUTLER.SCH	Name PnM Ver-a STATUS.SCH	Name PnM Ver-A DISPLAY.SCH
[Green Box]	[Green Box]	[Green Box]

Sheet 1 of 4

Ver A 140907

NOTE: Text on connection lines is a Net Name. Nets with SAME name are joined together. PARTS PREFIXED WITH 500, HAVE BEEN ADDED. (star mods) There are 3 sheets in this project.

COMMERCIAL-IN-CONFIDENCE NOT TO BE DISCLOSED WITHOUT WRITTEN AUTHORITY		
Pic N Mix DDS BY G3XJP		
Title: PicnMix	Number: A3	Issue: Ver A Panel
Printed on: 31-Oct-2007 13:17:59	Sheet 1 of 4	Issue: Ver A Panel

+5v comes from IC2 voltage regulator

Ensure BC327's are inserted correctly as PCB overlay is incorrect !

NB: this pinout suits the keypad VK3PE used.
Check yours !!

You may need to make a cable to interconnect to your Keypad.

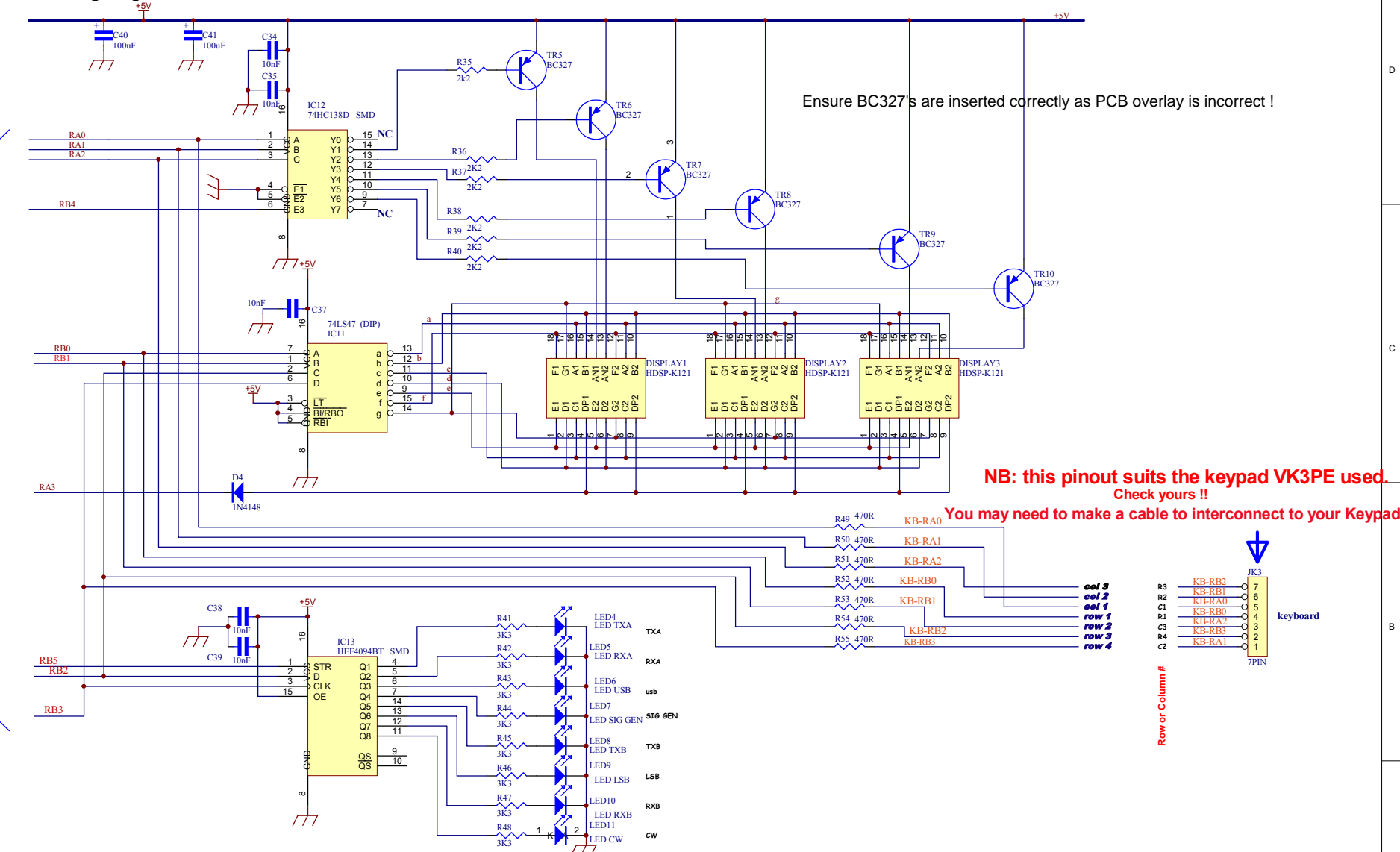

This schematic is a re-drawn version of the G3XJP PnM schematic who owns the (C). This schematic is provided for completeness only for the VK3PE & C.S. pcb.

Sheet 2 of 4

NOTE: Text on connection lines is a Net Name.
Nets with SAME name are joined together.
There are 4 sheets in this project.

Ver A 140907

NAMES ON LINES GOTO LIKE NAMES ON SHEET 1

Updated on:	Updated by:
	230707
COMMERCIAL-IN-CONFIDENCE NOT TO BE DISCLOSED WITHOUT WRITTEN AUTHORITY	
Title:	PIC12C01 DISPLAY AND KEYBOARD INTERFACE
Size:	Number:
A3	A
Issue:	
Printed on:	31-Oct-2007 13:19:21
Sheet 2 of 4 F:\PnI-2208\PnM\VER A SCHEMATICS\Update-1 311007\PnM_Ver-A_DISPLAY.SCH	

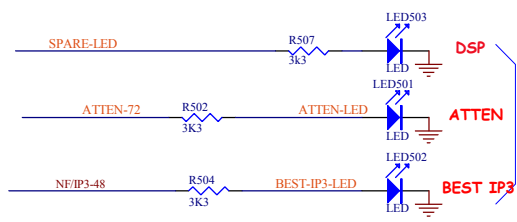
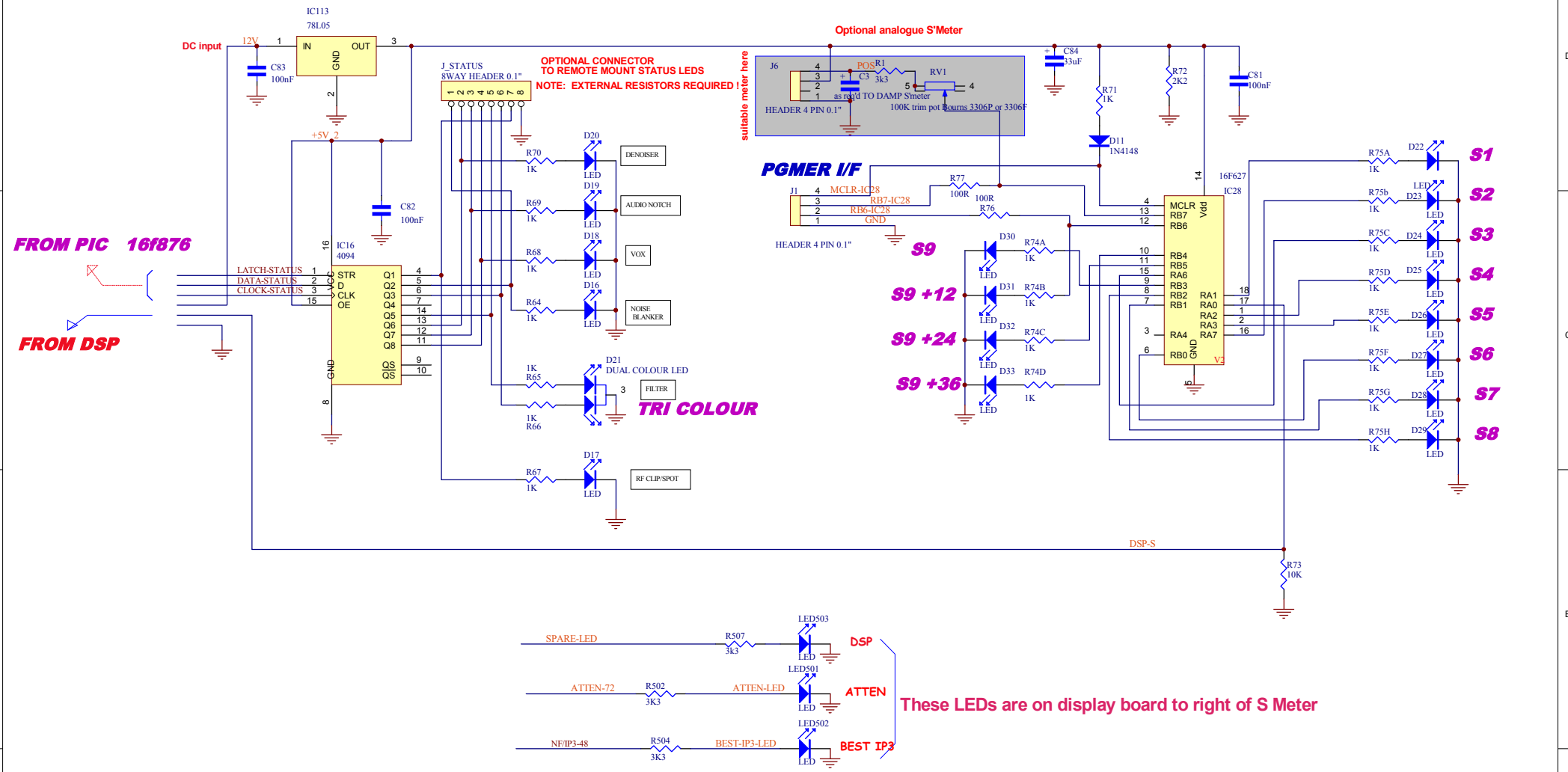

These LEDs are on display board to right of S Meter

Sheet 3 of 4

Ver A 140907

This schematic is a re-drawn version of the G3XJP PnM schematic who owns the (C). This schematic is provided for completeness only for the VK3PE & C.S. pcb.

VK3PE 10-07-06			
STAR STATUS PCB			
Updated on:		Updated by:	
COMMERCIAL-IN-CONFIDENCE NOT TO BE DISCLOSED WITHOUT WRITTEN AUTHORITY			
Title: PICNMIX status section			
Size: A3	Number:	Issue: A	
Printed on: 31-Oct-2007 13:20:07		Sheet 3 of 4	
File: F:\Pnl-2208\PnM\VER A SCHEMATICS\Update-1 311007\PnM_Ver-a_STATUS.SCH			

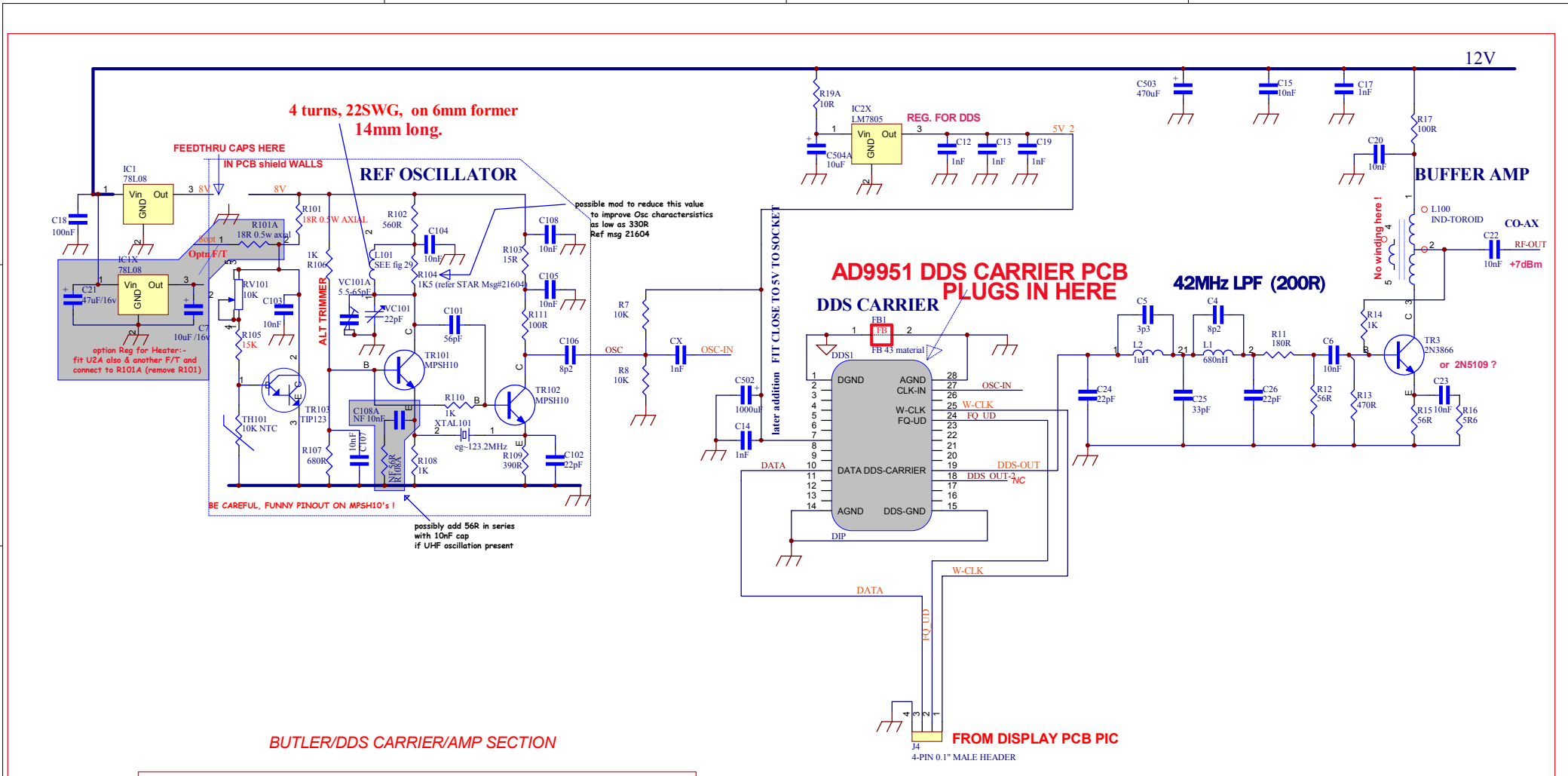

BUTLER/DDS CARRIER/AMP SECTION

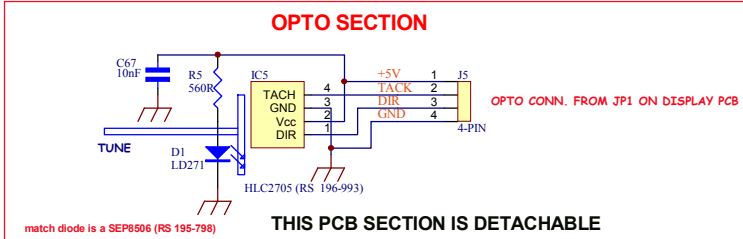

BUTLER OSC, DDS CARRIER AND AMP PCB

Ver A 140907 Sheet 4 of 4

This schematic is a re-drawn version of the G3XJP PnM schematic who owns the (C). This schematic is provided for completeness only for the VK3PE & C.S. pcb.

31-10-07 C2 IS ON DISPLAY PCB	
Updated on:	Updated by:
COMMERCIAL-IN-CONFIDENCE NOT TO BE DISCLOSED WITHOUT WRITTEN AUTHORITY	
Title: PICNMIX BUTLER SECTION	
PCB file name:	Size: A3
Number:	Issue: A
Printed on: 31-Oct-2007 13:20:52	
File: F:\PnI-2208\PnM\VER A SCHEMATICS\Update-1 311007\PnM_Ver-a_BUTLER.Sch	